

高速表面封裝型電子零件生產設備 TS-300

High Speed Processing System for SMD Component

結合測試印字打帶

Compact Test, Mark, Tape & Reel

高效率 低噪音 低損耗
Efficient, Noiseless, Hard-Wearing

- ▲生產產品：
SMD 表面封裝型及 CHIP 晶片型各式電子零件均適用
- ▲產能：18,000--19,200uph
- ▲振動盤散裝下料
- ▲測試模組-10 組（可視需要更改）
- ▲排料模組-10 組（可視需要更改）
- ▲雷射印字模組
- ▲印字檢測
- ▲打帶模組-2 組（可視需要更改）

- ▲Products：SMD, Chip component
- ▲Capacity：18,000--19,200uph
- ▲Bowl Feeding (Bulk)
- ▲Testing – 10 Module (Change with demand)
- ▲Sorting – 10 Modules (Change with demand)
- ▲Laser Marking
- ▲Mark Inspection
- ▲Taping – 2 Modules (Change with demand)



(本圖片僅供參考 This photo for reference)

TS-300 是全自動將表面封裝型電子零件由散裝而至成帶包裝的設備，藉由真空吸嘴盤的運轉而將產品穩定而快速的送至各工作站作測試、印字、分類、包裝之工作。

此設備可加裝視覺檢測系統，用以檢測零件表面、底部的導線以及印字清晰等。而依客戶不同的需求，可聯結市面上各式的雷射印字系統舉凡 Nd:YAG lamp, diode pumped, Co2 等。

本機講求低噪音、低震動、低損耗，運轉靈活，並富有彈性，多項專利設計，生產速度可達 19,200uph。機械上各工作站模組化設計均可簡易且快速的更換規格，便於未來的擴充，以及方便操作人員進行維修及保養。

The TS-300 is automatic machine of bulk to tape for SMD electronic components, via vacuum nozzle plate rotating to transport components to the respective station testing, marking, sorting and taping at speedy operation.

Optionally, it can be connected to a vision inspection to check surface, lead, mark of components. Depend on customer demand, it can be integrated nearly all laser marking systems like Nd:YAG lamp, diode pumped, Co2 etc..

This machine stressed low noise, low vibrate, low wearing, capacity up to 19,200uph. Modular system, flexible applications for future expansion, easy operation and easy spec changes for operator.

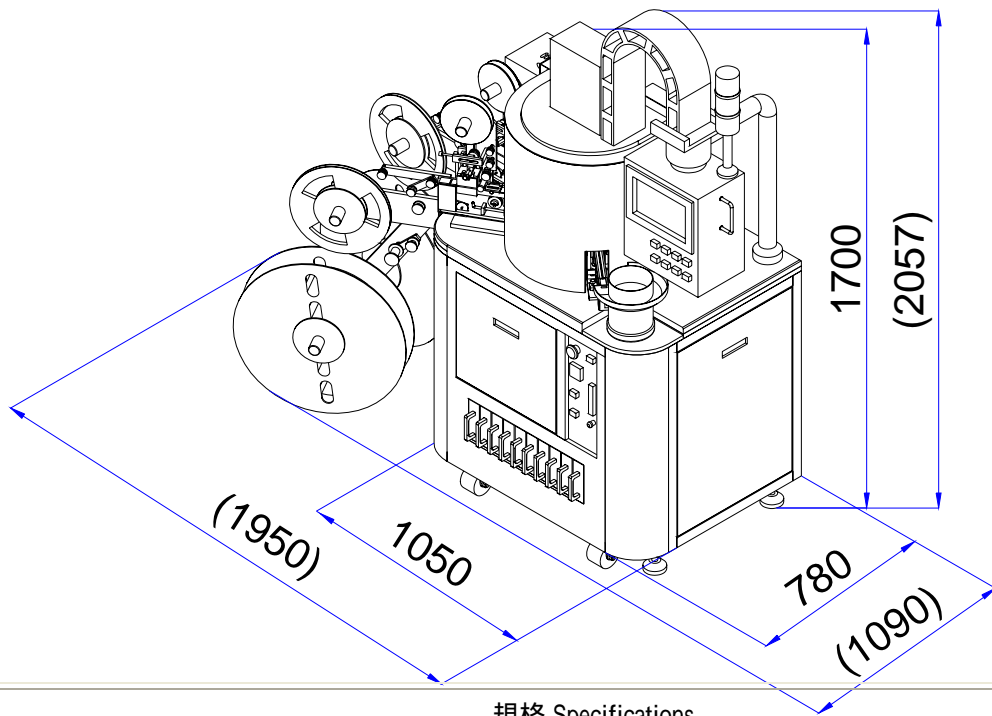

規格 Specifications

適用產品 Applicable Parts	各式晶片型，SMD 表面封裝型電子零件 Various kinds of chip and SMD components
零件供給 Components Supply	散裝零件，振動盤入料 Bulk components, vibratory bowl feeder
測試 Testing	無動力隨插即用型測試模組 9 組，適用於各種測試儀器的介面 Without power and plug & play testing modules 9sets, any kind of tester interface adaptable.
雷射印字 Laser Marking	可依據測試結果作多種印字，可連結各種系統的印字機 Multiple marking according to test result possible, interface for nearly all industrial laser marking systems
視覺檢查 Vision Inspection	可連結各種系統的視覺檢查器 Interface for nearly all industrial vision inspector
排除 / 分類 Rejecting / Sorting	隨插即用型排除模組，使用空氣吹除不良品 A lot of plug & play sorting modules, with air blow to reject components
打帶 Taping	兩組隨插即用型打帶模組，使用可調溫的熱壓封口。並包含自動切換系統，當一組滿料後，自動切換至第 2 組打帶模組。 2 set of Plug & play type taping modules, Thermo compression sealing with adjustable temperature control, and including auto switch over function- When 1 tape is full that will auto switch to another taping modules without downtime.
成品帶 Carrier Tape	8 / 16 mm
電力供給 Power Requirements	220/380 VAC, 50/60 Hz
真空源 Vacuum Source	內建真空幫浦 Vacuum Pump (built-in)
外觀尺寸 Outside Dimensions	1,670(L) x 780(W) x 1,800(H) mm

TONSAN

通山機械股份有限公司

台北縣樹林市忠義街 18 號

<http://www.tonsan.com.tw>

TEL:886-2-26894631

FAX:886-2-26896040

E-MAIL: sales@tonsan.com.tw

TONSAN MACHINERY CORP.

NO.18, CHUNG YIH ST., SHU LIN CITY,

238 TAIPEI HSIEN, TAIWAN.

<http://www.tonsan.com.tw>

TEL:886-2-26894631

FAX:886-2-26896040

E-MAIL: sales@tonsan.com.tw